



C.L-CNC-600G

钻攻机三轴、四轴、五轴

Drilling and tapping machine three-axis, four-axis, five-axis

功能

全自动钻攻系列，是生产五金、钟表、手机等等行业最新型的快速加工全自动设备。

Functions

It is the full-automatic drilling and tapping series, and the newest full-automatic rapid processing equipment in the production of hardware, clocks and watches, mobile phone and other industries.

优点

- 省人、省事、省时间，一次性加工到位。
- 高精度度，所有尺寸标准统一。
- 人性化操作系统，进口配置，功能齐全，执行命令快速无误。
- 全自动夹具，调节方便，配备全缓冲系统，快速安全。

Advantages

- It can save labor, trouble and time, and realize the one-time processing.
- The precision is high, and all sizes are standard and unified.
- It has the humanized operating system, imported configuration and complete function, and executes the command fast and accurately.
- The automatic fixture adjustment is convenient, and it is equipped with the full buffer system, quick and safe.

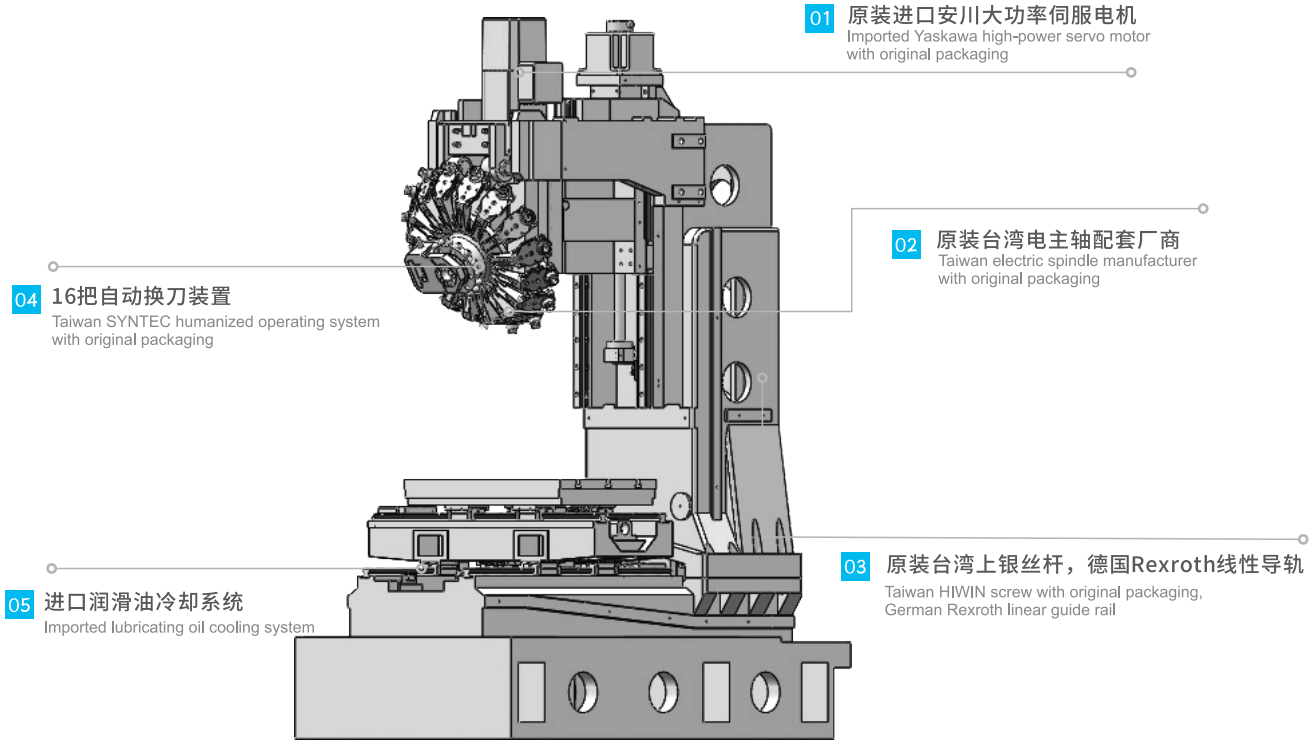

01 原装进口安川大功率伺服电机
Imported Yaskawa high-power servo motor with original packaging

02 原装台湾电主轴配套厂商
Taiwan electric spindle manufacturer with original packaging

03 原装台湾上银丝杆，德国Rexroth线性导轨
Taiwan HIWIN screw with original packaging, German Rexroth linear guide rail

04 16把自动换刀装置
Taiwan SYNTEC humanized operating system with original packaging

05 进口润滑油冷却系统
Imported lubricating oil cooling system



技术参数 / Technical Parameters

| 性能指标项 Performance index | 标准值 standard value | 刀柄规格 Shank mode | Bt30 |
|--|-----------------------|--|-------------------------------|
| 工作台面积 Positional accuracy of X/Y/Z axes movement | 700*420mm | 工作电压 Working voltage | 380V/三相 380 V/ Three-phase |
| X、Y、Z轴运动定位精度 Positional accuracy of X/Y/Z axes movement | 0.015mm | 主轴转速 Spindle speed | 20000-24000rpm |
| X、Y、Z轴重复定位精度 The accuracy of repetitive positioning of X/Y/Z/A axes | 0.010mm | 三轴快速移动 Three-spindle fast moving | 48m/min |
| X、Y、Z轴工作行程 Operating stroke of X/Y/Z axes | 600mm*400mm*300mm | 工作台最重载重量 Largest carrying capacity of workbench | 300KG |
| 主轴端面至工作台面的距离 Distance from spindle face to workbench surface | 115-450 (加高型300-600) | 床体重量(KG) Machine tool weight(KG) | 3000KG |
| 主轴孔锥度及主轴套外径 Spindle taper and spindle sleeve outer diameter | BT30/φ95 | 机床尺寸 Machine dimension | 1800*2150*2000mm |